

DATAVS2 SERIES

The **DATAVS2** vision sensor series presents all the characteristics able to solve artificial machine vision applications in a flexible and intuitive way. **DATAVS2** is a completely embedded device: the optic, the red LED illuminator and the electronics are included in an extremely compact housing. The sensor is configured via PC through Ethernet communication. The configuration software is included in the product and it has been developed in order to lead the customer through the configuration process step by step. **DATAVS2** is available in three different versions according to the installed control tools: **Object Recognition (OBJ)**, **Advanced Object Recognition (AOR)** and **Identification (ID)**. Many different control typologies are available: brightness, contrast, position, width, count, pattern match, contour match, 360° pattern match, barcode and datamatrix reader, OCV.



VISION



HIGHLIGHTS

- Flexible and intuitive setup via PC through Ethernet
- Memorisation of 20 inspections
- 11 different controls
- 360° pattern match for Advanced models
- Logical operators: AND, OR, NOT, NAND, NOR, etc.
- TURBO mode to double elaboration speed
- VSM compatibility

APPLICATIONS

DATAVS2 is ideal for the control of text presence in overprinting and logo position on food packages, product completeness before packaging, logo position on cosmetic bottles, correct stamp on post envelopes, liquid level inside a plastic bottle, correct product orientation on a conveyor belt, barcode and datamatrix reading.

Stamp control



Part orientation



Overprinting

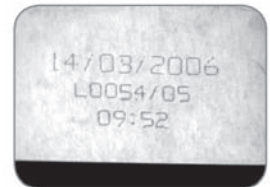

Level control

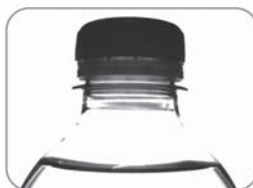

Logo control



Barcode & Datamatrix



The extremely compact size of the DATAVS sensors is not an obstacle for the full integration of all the elements for a reliable image-based control.

- Compact housing
- Red light LED illuminator
- Selectable lenses
- Focus knob
- Standard M12 connectors
- Ethernet communication
- 3+1 PNP outputs
- 4 signalling LEDs: output1, output2, power supply, communication
- Teach push-button
- 640x480 pixel greyscale image sensor



DIMENSIONS

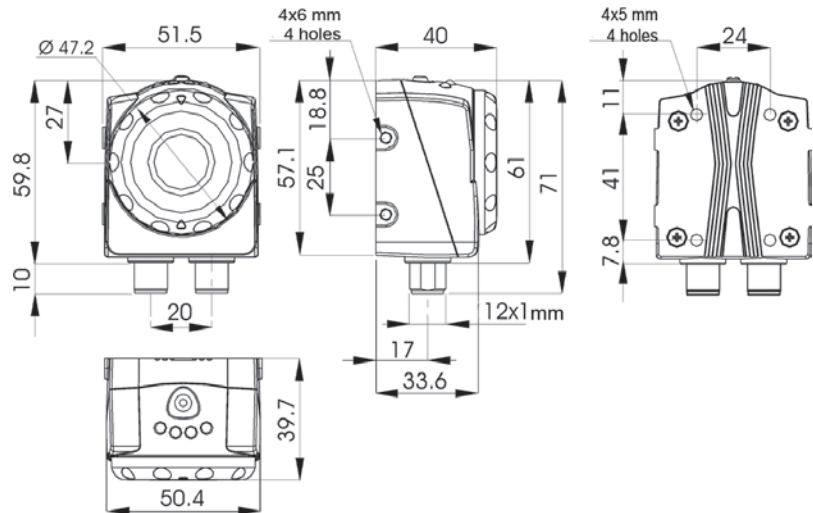

INDICATORS AND SETTINGS

Teach push-button with double function:

- reference image update
- recovery mode



- A** Power supply, green
- B** Digital output 1, orange
- C** Digital output 2, orange
- D** Network connection, green

CONNECTIONS



M12 4-pole Ethernet

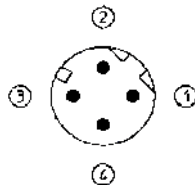

- 1 = white/orange = RX+
- 2 = white/green = TX+
- 3 = orange = RX-
- 4 = green = TX-

M12 8-pole (power supply and I/O)

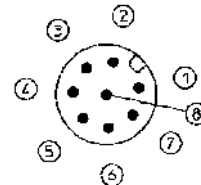

OBJ and AOR models

- 1 = white = digital input 1
- 2 = brown = 24 Vdc
- 3 = green = configurable output
- 4 = yellow = output 1
- 5 = grey = output 2
- 6 = pink = output 3
- 7 = blue = GND
- 8 = red = external trigger

ID models

- 1 = white = RS232 RX
- 2 = brown = 24 Vdc
- 3 = green = configurable output
- 4 = yellow = output 1
- 5 = grey = output 2
- 6 = pink = RS232 TX
- 7 = blue = GND
- 8 = red = external trigger

TECHNICAL DATA

Power supply:	24 Vcc ±10 %
Ripple:	1 Vpp max with illuminator 2 Vpp without illuminator
Consumption:	100 mA at 24 Vdc (without illuminator)
Output type:	3+1 PNP
Output current:	100 mA max
Saturation voltage:	< 2 V
Network interface:	M12 4-pole Ethernet 10/100 Mbs
Serial interface:	RS232 (only ID models)
External illuminator interface:	Strobe signal (24 V PNP N.O.)
Frame rate:	60 fps
Optics:	integrated (6 mm / 8 mm / 12 mm / 16 mm)
Setting:	TEACH push-button
Indicators:	4 LED
Connections:	M12 8 pole A-code M12 4 pole D-code
Mechanical protection:	IP50
Protection devices:	A, B
Housing material:	aluminium alloy / ABS
Weight:	125 g
Operating temperature:	-10 ... +50°C
Storage temperature:	-25 ... +70°C

TECHNICAL NOTES

¹Limit values
²A - reverse polarity protection
 B - overload and short-circuit protection



FIELD OF VIEW

OPERATING DISTANCE (mm)	FIELD OF VIEW (Width x Height) in mm			
	DATAVS2-16-xx-xxx	DATAVS2-12-xx-xxx	DATAVS2-08-xx-xxx	DATAVS2-06-xx-xxx
50	-	17 x 12	25 x 20	42 x 30
80	-	25 x 20	40 x 30	60 x 41
110	-	33 x 25	55 x 40	80 x 55
140	31 x 24	45 x 35	70 x 50	98 x 69
170	39 x 29	53 x 38	85 x 60	118 x 83
200	46 x 34	60 x 50	100 x 70	138 x 92
300	70 x 53	90 x 65	145 x 103	201 x 140
400	94 x 71	121 x 82	186 x 132	265 x 189
500	118 x 89	150 x 110	236 x 167	330 x 232
600	143 x 107	185 x 130	282 x 232	385 x 270

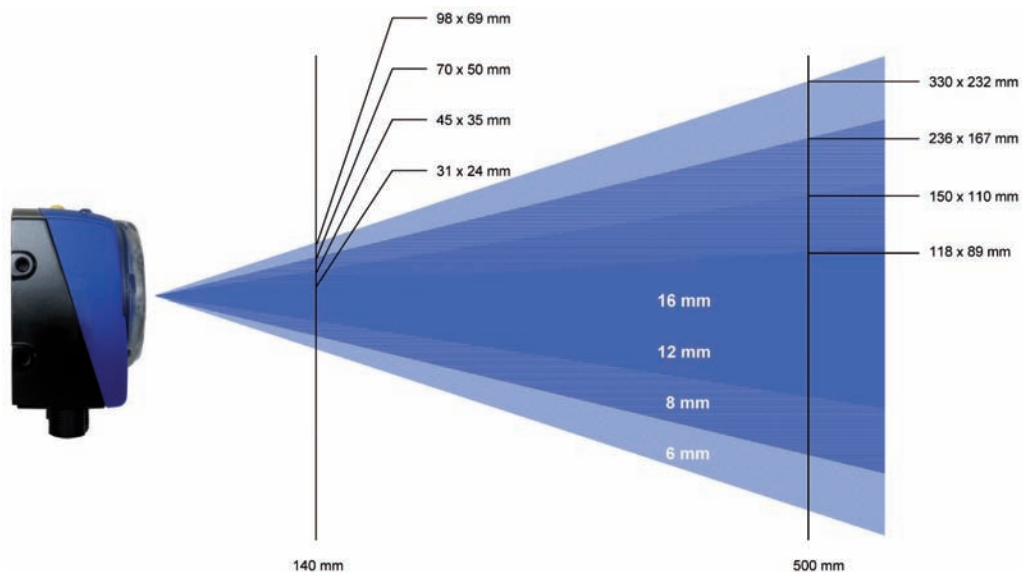

SOFTWARE PC

Main menu

Wizard set up

Image buffer

Control panel

Help online

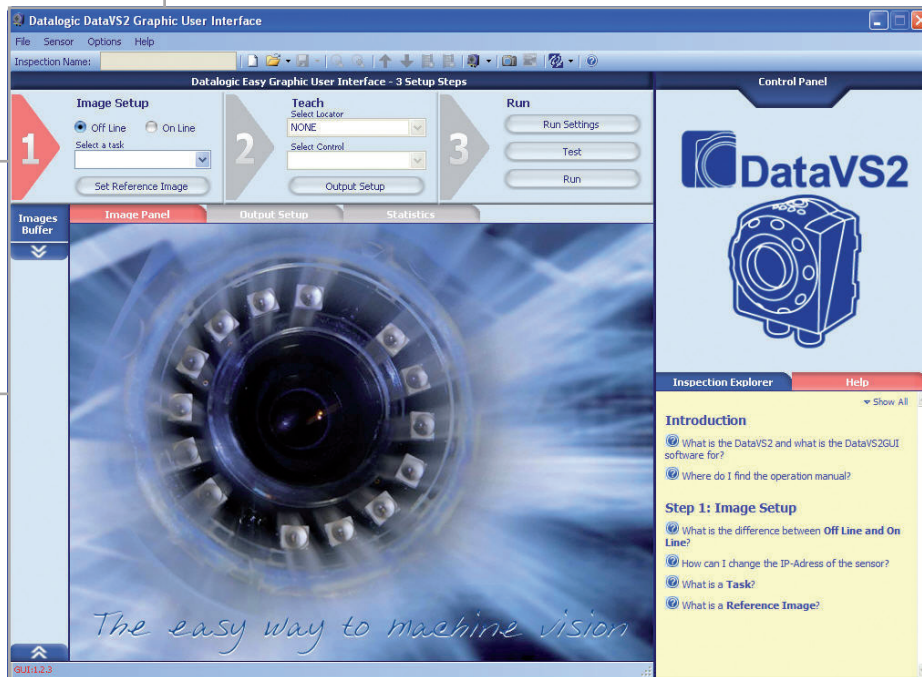

Status bar

Step 1: Image Setup

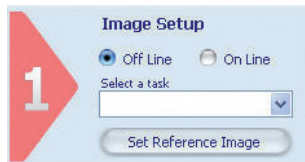

The first step consists in connecting the sensor and configuring the image quality parameters. When the desired results are obtained, the user can memorise the image that will be used as a template during sensor functioning.

Step 2: Teach



The second step establishes the acceptance criteria to distinguish objects from wastes. One or more controls can be selected according to the task to carry-out.

Step 3: Run

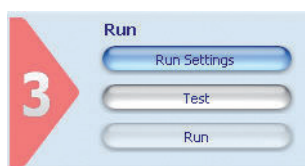

The third step configures the sensor digital outputs, simulates sensor functioning on the PC to verify the controls chosen and activates the operating phase on the sensor using the PC only to control the diagnostics.

MAXIMUM SIMPLICITY



Discovery

The Discovery function finds all the sensors connected to the network.



Help

A Help is available for each step, supplying useful suggestions on the options available.

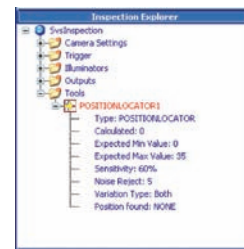

Inspection explorer

All the parameters connected to the inspection are grouped together and can be easily reached by the user.

Inspection selection

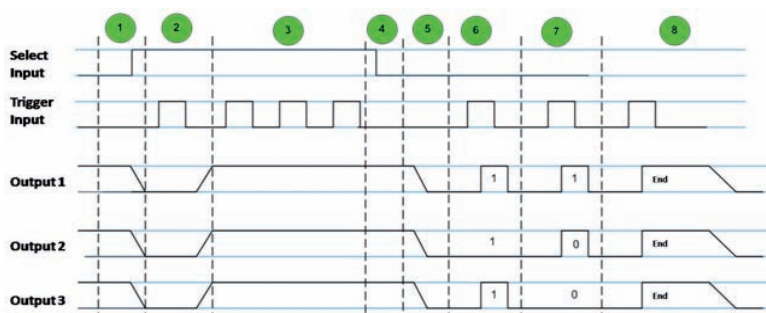

Each inspection is composed of a template and parameters. A specific inspection can be thus referred to different products in progress on the same production line.

The different inspections can be recalled using digital pulses or through an Ethernet or RS232 command. Different inspection selection protocols with or without acknowledge are available.

Statistics

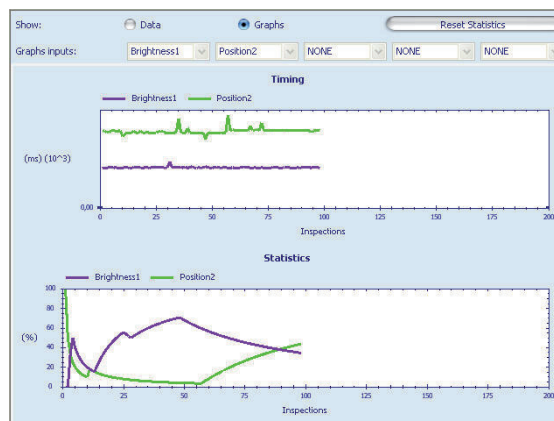

The statistics panel displays all the information about inspection results and execution time. Data can be shown also in a graph.



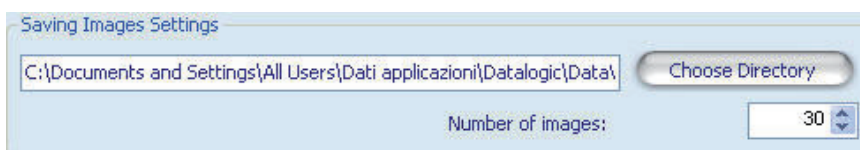

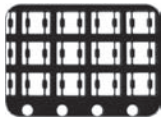

Image saving



The image saving panel allows to set a folder where the acquired pictures are stored. An image saving condition can be also specified.

CONTROL TABLE

Object Recognition

Seven different controls able to cover the most varied applications.			
Control	Functioning	Applications	Image
Pattern Match	Searches a sample inside a specific area	<ul style="list-style-type: none"> • Packaging: logo check • Assembling: product orientation • Post automation: stamp check 	
Contour Match	Shape control	<ul style="list-style-type: none"> • Metal working: integrity control • Food: coffee waffle shape control 	
Position	Check of object border position	<ul style="list-style-type: none"> • Bottling: liquid level control: • Food: label position control 	
Width	Measures object width	<ul style="list-style-type: none"> • Assembling: plastic part control • Wood industry: branch thickness measurement 	
Counting	Counts the objects along a line	<ul style="list-style-type: none"> • Electronics: component counting • Pharmaceutical: blister stack counting 	
Contrast	Contrast calculation	<ul style="list-style-type: none"> • Food: date and lot presence control • Metal working: laser marking control 	
Brightness	Brightness calculation	<ul style="list-style-type: none"> • Bottling: cap presence control • Packaging: object counting 	

ADVANCED MODELS (AOR)

The Advanced Object Recognition (AOR) models integrate new important functionalities, including:



360° Pattern Match locator
Object detection independent from rototranslations.

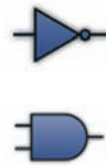

Logical tools
Possibility to combine the results of the single tools through boolean operator (AND, OR, NOT, etc.)



Advanced Ethernet
Current inspection results available also on Ethernet communication.





Speed-up
High execution speed thanks to the management of reduced resolution and TURBO mode.

360° Pattern match

The Advanced Object Recognition (AOR) models include all the controls and locators available on Object Recognition models as well as the new 360° Geometric Pattern Match Locator.

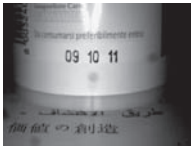

IDENTIFICATION MODELS (ID)

Control	Functioning	Image
Barcode reader	<p>Decode: read and decode one (or more) barcode in the Region Of Interest.</p> <p>String match: read and decode one (or more) barcode and compare it with a set of reference strings.</p> <p>Counter: count the number of barcodes in the Region Of Interest.</p>	
Datamatrix reader	<p>Decode: read and decode one (or more) datamatrix in the Region Of Interest.</p> <p>String match: read and decode one (or more) datamatrix and compare it with a set of reference strings.</p> <p>Counter: count the number of datamatrix in the Region Of Interest.</p>	
OCV	Verify the readability of printed characters	

Symbologies

	Codabar		UPC-A
	Code 39		UPC-E
	Code 128		PDF417
	EAN-8		Pharmacode
	EAN-13		Postnet
			IMB
	Interleaved 2 of 5		ECC200

ACCESSORIES

ST-5066
U-shaped fixing bracket for angle adjustment

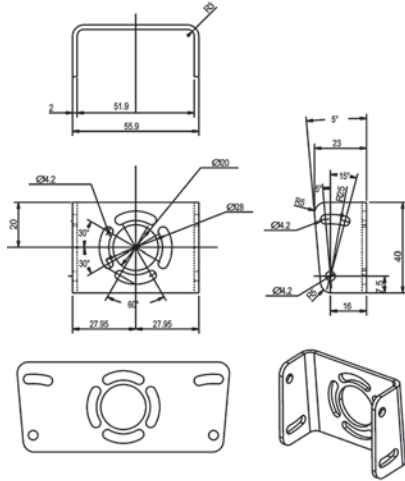

ST-5068
L-shaped fixing bracket for 90° mounting

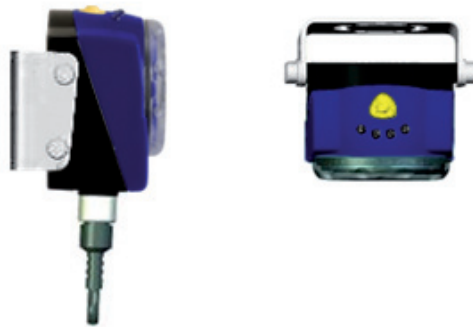
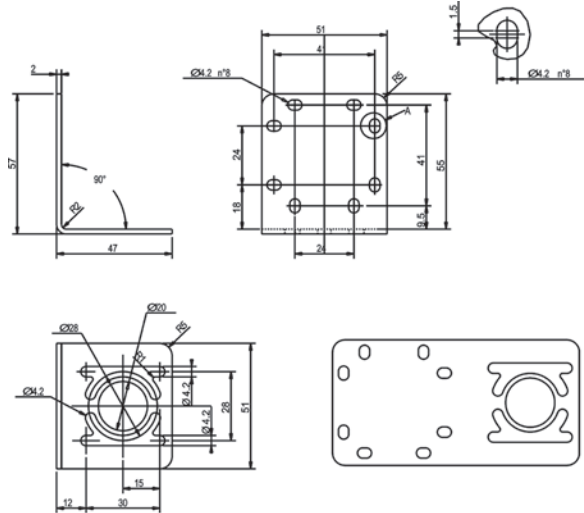

Mounting kit

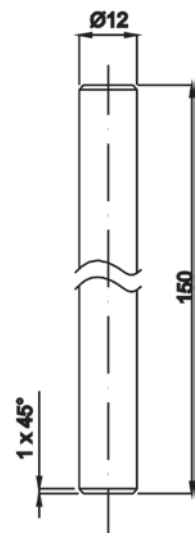
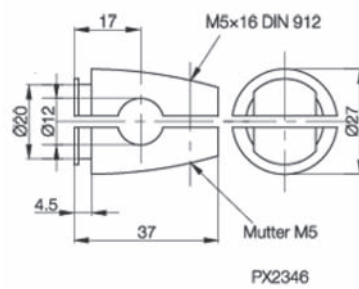
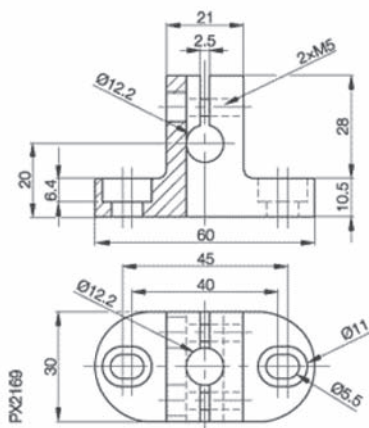

MODEL SELECTION TABLE

MODEL	SOFTWARE	LOGICAL TOOLS	ETHERNET	RS232	I/O	OPTIC	ORDER N°
DATAVS2-06-DE-OBJ	Object Rec.		Base		2 IN; 4 OUT	6mm	959951050
DATAVS2-08-DE-OBJ	Object Rec.		Base		2 IN; 4 OUT	8mm	959951060
DATAVS2-12-DE-OBJ	Object Rec.		Base		2 IN; 4 OUT	12mm	959951070
DATAVS2-16-DE-OBJ	Object Rec.		Base		2 IN; 4 OUT	16mm	959951030
DATAVS2-06-DE-AOR	Adv. Obj. Rec.	•	Advanced		2 IN; 4 OUT	6mm	959951000
DATAVS2-08-DE-AOR	Adv. Obj. Rec.	•	Advanced		2 IN; 4 OUT	8mm	959951010
DATAVS2-12-DE-AOR	Adv. Obj. Rec.	•	Advanced		2 IN; 4 OUT	12mm	959951020
DATAVS2-16-DE-AOR	Adv. Obj. Rec.	•	Advanced		2 IN; 4 OUT	16mm	959951040
DATAVS2-06-RE-ID	Identification	•	Advanced	•	1 IN; 3 OUT	6mm	959951130
DATAVS2-08-RE-ID	Identification	•	Advanced	•	1 IN; 3 OUT	8mm	959951140
DATAVS2-12-RE-ID	Identification	•	Advanced	•	1 IN; 3 OUT	12mm	959951120
DATAVS2-16-RE-ID	Identification	•	Advanced	•	1 IN; 3 OUT	16mm	959951190

ACCESSORY SELECTION AND ORDER INFORMATION

MODEL	DESCRIPTION	ORDER N°
CV-A1-36-B-03	M12 8-pin shielded cable 3m	95A255430
CV-A1-36-B-05	M12 8-pin shielded cable 5m	95A255440
CV-A1-36-B-10	M12 8-pin shielded cable 10m	95A255450
DATAVS-ST-5068	L-shaped fixing bracket for 90° mounting	95A901320
DATAVS-ST-5066	U-shaped fixing bracket for angle adjustment	95A901330
DATAVS-CV-RJ45C-03	3 m crossed Ethernet cable	95A901340
DATAVS-CV-RJ45D-03	3 m direct Ethernet cable	95A901350
DATAVS-MK-01	Mounting kit	95A901380



The company endeavours to continuously improve and renew its products; for this reason the technical data and contents of this catalogue may undergo variations without prior notice. For correct installation and use, the company can guarantee only the data indicated in the instruction manual supplied with the products.

