



label-aire®
labeling made easy

www.label-aire.com

Understanding the Basics of Automatic Pressure-Sensitive Labeling Methods

William Claproth
Director of Marketing Services
Label-Aire, Inc.



Ahearn & Soper Inc.
AUTO-ID SOLUTIONS
www.ahearn.com

Pressure-sensitive label applicator featuring air-blow technology.

Understanding the Basics of Automatic Pressure-Sensitive Labeling Methods

As consumer packaged goods (CPG) companies increasingly recognize how the flexibility of automatic pressure-sensitive labeling lowers operating costs and increases productivity, they are investigating the range of labeling application methods available.

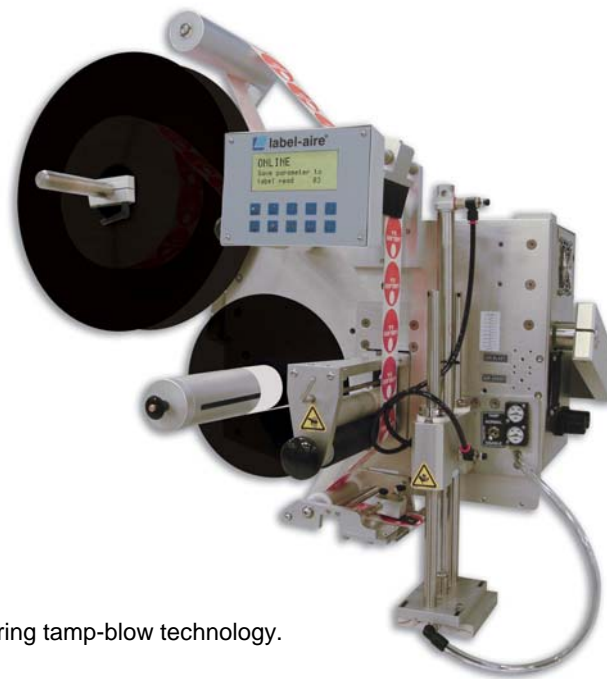

Pressure-sensitive label applicator featuring tamp-blow technology.

Prior to selecting a labeling application method, there are specific factors that must be determined to ensure that the unique characteristics of the application's attributes are considered. Once the information about those factors has been compiled, users can proceed to evaluating the various labeling methods.

There are three fundamental types of automatic pressure-sensitive labeling equipment: wipe-on, air-blow, and tamp-blow. With a basic understanding of how each labeling application method works, companies can determine which one best suits their needs and implement an optimal labeling solution.

Application Considerations

Before an appropriate automatic pressure-sensitive application method can be selected, the following questions must be answered to ensure that a specific labeling application's requirements are met:



Product profile: Is the surface area on which the label will be applied flat, concave, convex, or tapered?

Product material: Is the product plastic, metal, cardboard, glass, or some other type of material?

Product condition: Is the product empty, filled, hot, cold, or in some other state?

Label size and shape: What are the width, length, and shape of the label?

Label material: Is the label paper, film or a different type of material?

Application rate: How many products per minute will be labeled?

Accuracy requirements: What are the tolerances for label placement that must be met?

Label location: Where will the label be applied?





Wipe-On

Also referred to as “synchronous” and “merge” labeling, wipe-on is the most common pressure-sensitive labeling application method. At the precise moment the product passes by the applicator’s dispense edge, the label is quickly accelerated to match the speed of the product and is synchronously applied to the product’s surface by means of a brush or roller. The label is controlled through the whole process by the applicator.

Many of today’s marketers are taking advantage of the “no label” look of clear film and the wipe-on applicator is ideal for this type of product decoration. Opposing spring-steel backed rubber “squeegee” devices apply firm pressure to both sides of the product and squeeze out potential wrinkles and/or bubbles.

The wipe-on method has certain constraints that must be considered, including requiring that label and product speeds must be synchronized and the fact that the applicator must be mounted in the same direction as the product travels. Furthermore, an encoder is required to provide the electrical pulses necessary to synchronize the applicator to the product speed.

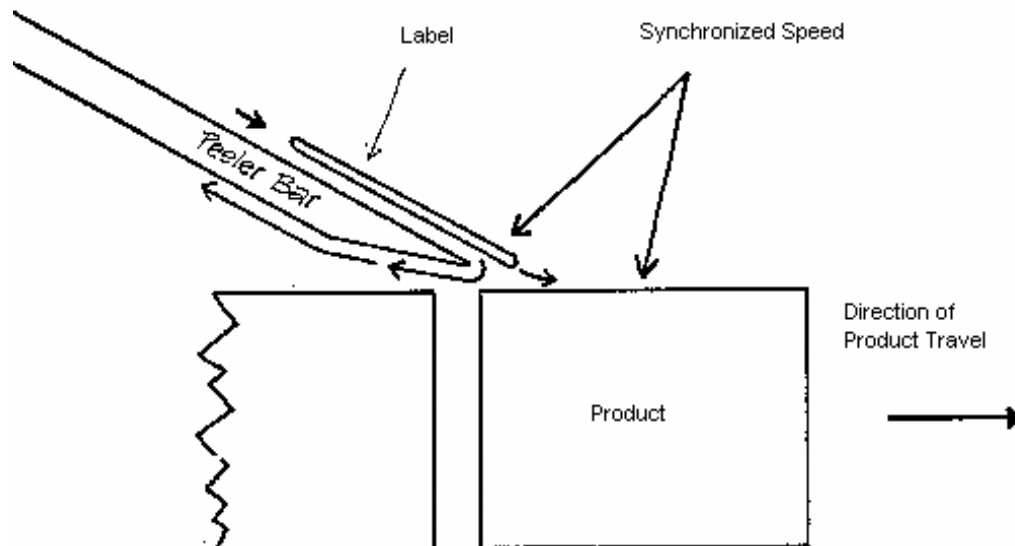



Air-Blow

Ideal for paper labels and coupons, the air-blow labeling method is a flexible alternative to the traditional wipe-on. An electric fan creates a vacuum to hold the dispensed label accurately onto a grid. At the precise moment the product passes under the grid, a pneumatic solenoid provides a controlled blast of compressed air to apply the label onto the product.

Not only is this technique capable of speeds up to 1,000 labels per minute, but it also adjusts for different label sizes by altering the pattern of the air blast so no change parts are required. Since labels are applied without making product contact, it is a practical solution for labeling food or fragile products. With its ability to pre-dispense labels, there is no need to match the speed of the product. It offers users flexibility because labels can be positioned either inline or even at 90 degrees of product travel.

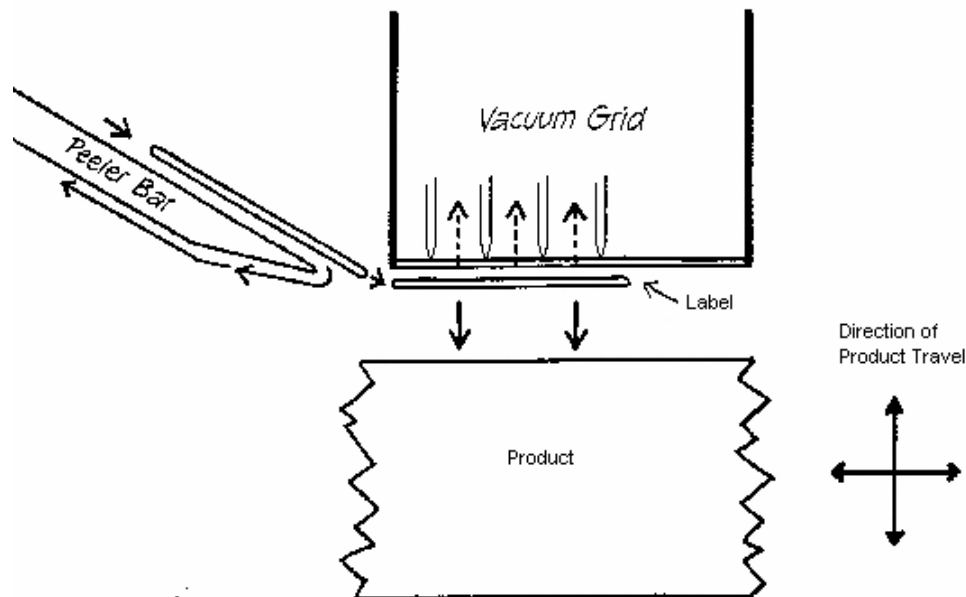



Tamp-Blow

This application method shares many of the attributes of the air-blow labeling method, but is most effective at applying small labels (0.25" – 1.0") very accurately. A venturi vacuum holds the dispensed label onto a pad that is sized to the label. A pneumatic tamp cylinder moves the pad toward the product. A pneumatic solenoid provides a controlled blast of compressed air to apply the label onto the product.

There are a number of advantages to this method. For example, it is very easy to set up, the vacuum pads are interchangeable to adjust to different label sizes, and tight or small target areas such as recessed panels on products can be reached. Since labels are pre-dispensed, there is no need to match the speed of the product or the conveyor. In addition, while labeling application speed is slower and a change pad is required, this method enables labels to be positioned from either inline of, reversed of, or at 90 degrees of product travel.

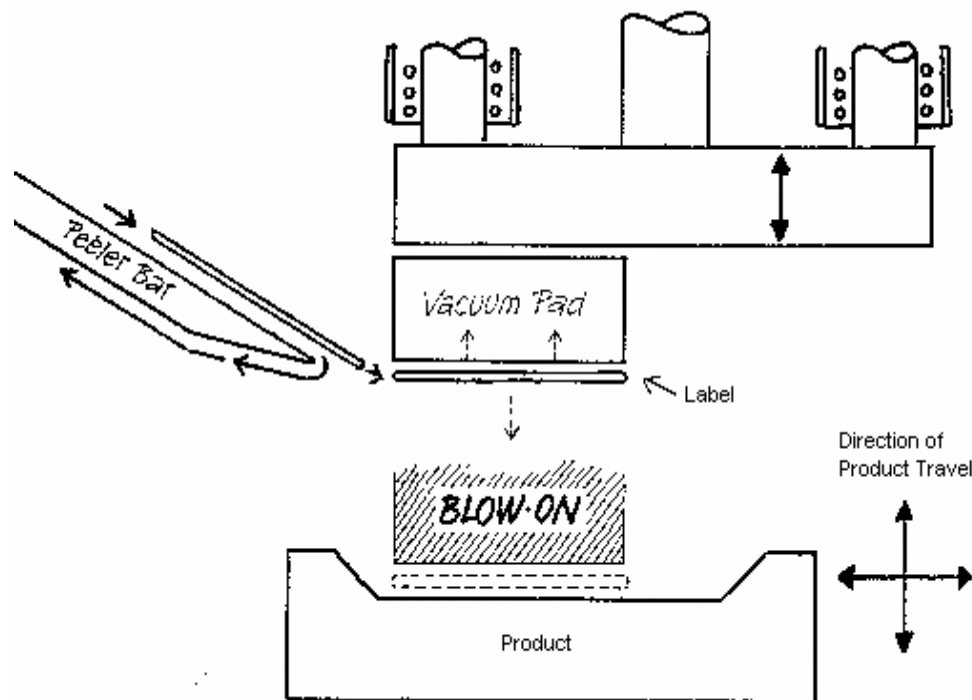



Custom

To fit specific products or operational parameters, applicators can have unique designs to best meet the needs of the labeling process. There are variations on the three fundamental general applicator types to apply labels to tapered containers, cartons or boxed products, including vacuum grid wipe-on, swing arm tamp and corner wrap.

The vacuum grid wipe-on method transfers the label to a vacuum grid before it is wiped onto the product. This technique is usually specified for applications requiring the labeling of tapered containers.

Swing arm tamp is designed to apply labels to either the front or side panel of a carton that is moving or stationary. Orientation of the label applicator can be above the carton or to the side of it, depending on label rolls, location of labels and the location of the carton. In either case, the applicator should be as close to the target area as possible to minimize the distance the applicator must travel.

Corner wrap applies labels to two sides of a carton. Labels are fed onto the vacuum grid after a sensor detects the product. The label needs to be fully dispensed before application. After the label is applied to the front panel, the applicator pivots around the corner of the carton, wiping it down the side panel. Corner wrap applicators are typically designed to work with a specific label size. The vacuum that holds the label in place can be generated by a venturi or high volume fan, which is determined by the specifics of the application and label size.

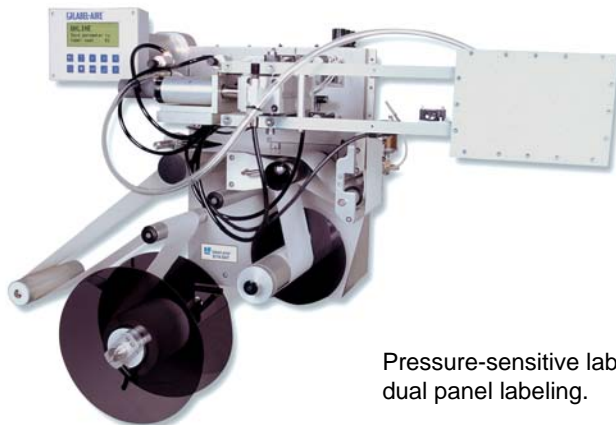

Pressure-sensitive label applicator featuring a swing arm tamp for dual panel labeling.

CPG companies have a range of choices when it comes to selecting the pressure-sensitive labeling application method that best fits their specific needs. Whether the requirement is as straightforward as a single label on a flat panel box or as challenging as a full wrap label on a tapered container, there is an application solution that will fit the need.

To see a video demonstration detailing how each of the automatic pressure-sensitive labeling applicators operate, visit www.label-aire.com/tech_info/demos.cfm



Pressure-sensitive label applicator featuring wipe-on technology.

For More Information Contact:
Label-Aire, Inc.
550 Burning Tree Road, Fullerton, CA 92833 USA
714 449-5155
714 526-0208 (Fax)
info@label-aire.com
www.label-aire.com

Distributed by:
Ahearn & Soper
100 Woodbine Downs Blvd.
Toronto, ON M9@ 5S6 Canada
416 675-3999
800 263-4258 (Toll Free)
Salesdept@ahearn.com
www.ahearn.com